



Appreciating Quality Automation

We at "DOLPHIN AUTOMATION" thank you for the purchase of this product and we assure you for our best services.....always!

### ON / OFF DELAY TIMER OPERATING INSTRUCTIONS DT 38

#### Specification :-

- 1. Size : 72X72X72 (all in mm)
- 2. Display : .56" for proportional value and .48" for set value
- 3. Range : 0.01 Sec to 9999 hours
- 4. Control Action : on delay/Interval
- 5. Setting : via Soft Keys
- 6. Power supply : 220 VAC ± 15% 50Hz
- 7. Mounting : Panel Mounting.
- 8. Operating Temps : 0-50° C.
- 9. Housing : ABS Plastic

#### Set Point

Set Point can be viewed by pressing **SET** KEY.

Set Point can be changed by pressing **SET** KEY + **▼** & **▲** KEYS

## Programming the Delay Timer

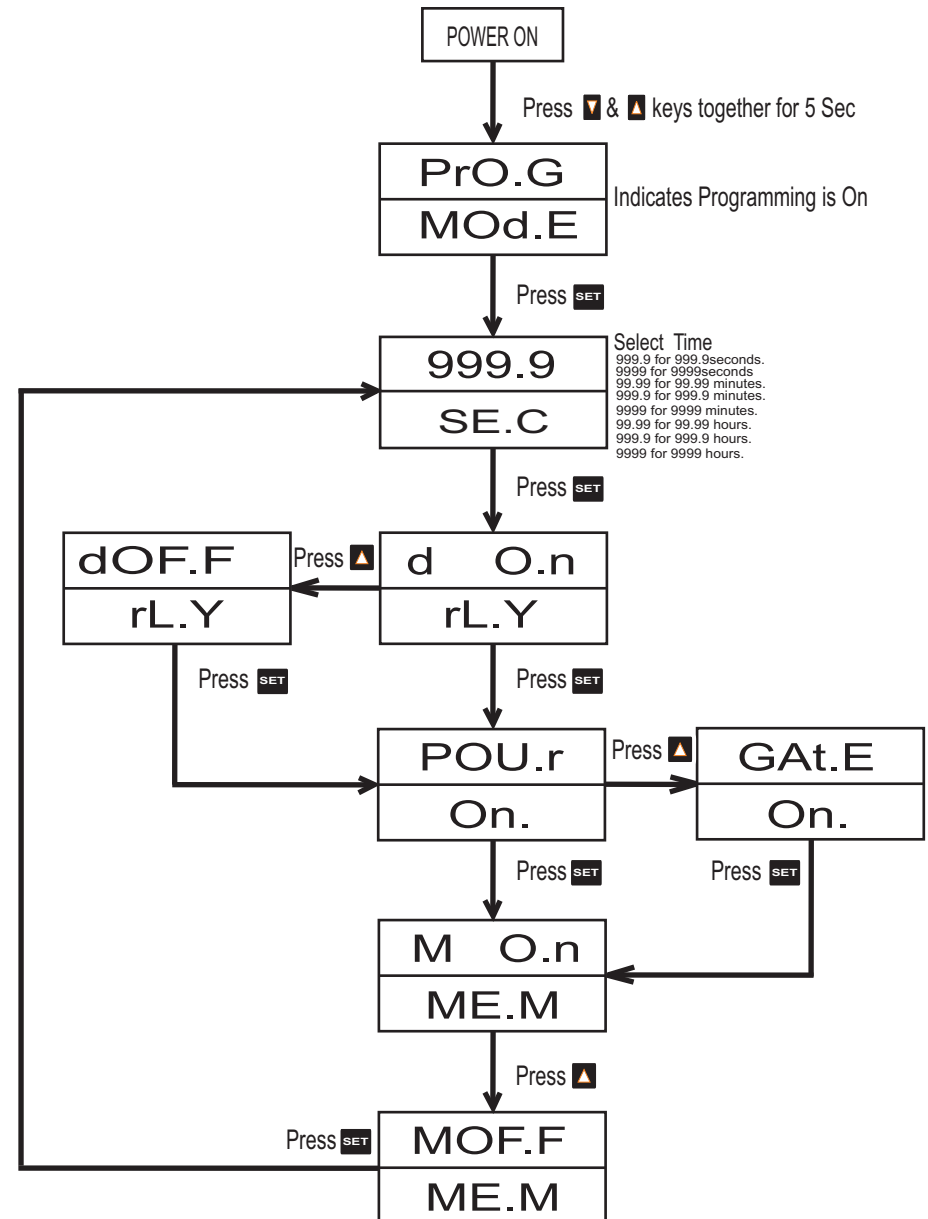

## Programming the Delay Timer

### ON / OFF DELAY TIMER

### OPERATING INSTRUCTIONS

#### Specification :-

- |                    |  |
|--------------------|--|
| 1. Size            | : 72X72X72 (all in mm)                               |
| 2. Display         | : .56" for proportional value and .48" for set value |
| 3. Range           | : 0.01 Sec to 9999 hours                             |
| 4. Control Action  | : on delay/Interval                                  |
| 5. Setting         | : via Soft Keys                                      |
| 6. Power supply    | : 220 VAC ± 15% 50Hz                                 |
| 7. Mounting        | : Panel Mounting.                                    |
| 8. Operating Temps | : 0-50° C.   |
| 9. Housing         | : ABS Plastic  |

#### Set Point

Set Point can be viewed by pressing **SET** KEY.

Set Point can be changed by pressing **SET** KEY + **▼** & **▲** KEYS

