



Appreciating Quality Automation

We at "DOLPHIN AUTOMATION" thank you for the purchase of this product and we assure you for our best services.....always!

Digital Temperature Controller

OPERATING INSTRUCTIONS TC-M81/K81/N81

Specifications :-

- 1. Display : .39" for PV & .20" for SV
- 2. Range : RTD Type -99.9 to 399.9 deg
J Type - 0- 600 deg
K Type 0 -1300 deg
- 3. Resolution : 1 deg(J/K) and 0.1 deg (RTD)
- 4. Accuracy : +/- 0.5% (Full Scale)
- 5- Hysterisis : 0 to 99°C
- 6. OFFSET : -99 to 99°C
- 7- Relay Action : Heat / Cool Selectable
- 8. Control Action : ON / OFF or Proportional

CYCLE TIME	: 1-99 Sec
Prop Band	: 0-99°C

Terminal Connection

- 1-Connect terminals of the controller according to the terminal connections

Set Point

Set Point can be viewed by pressing **SET** KEY.

Set Point can be changed by pressing **SET** KEY + **▼** & **▲** KEYS

Programming the Temperature Controller

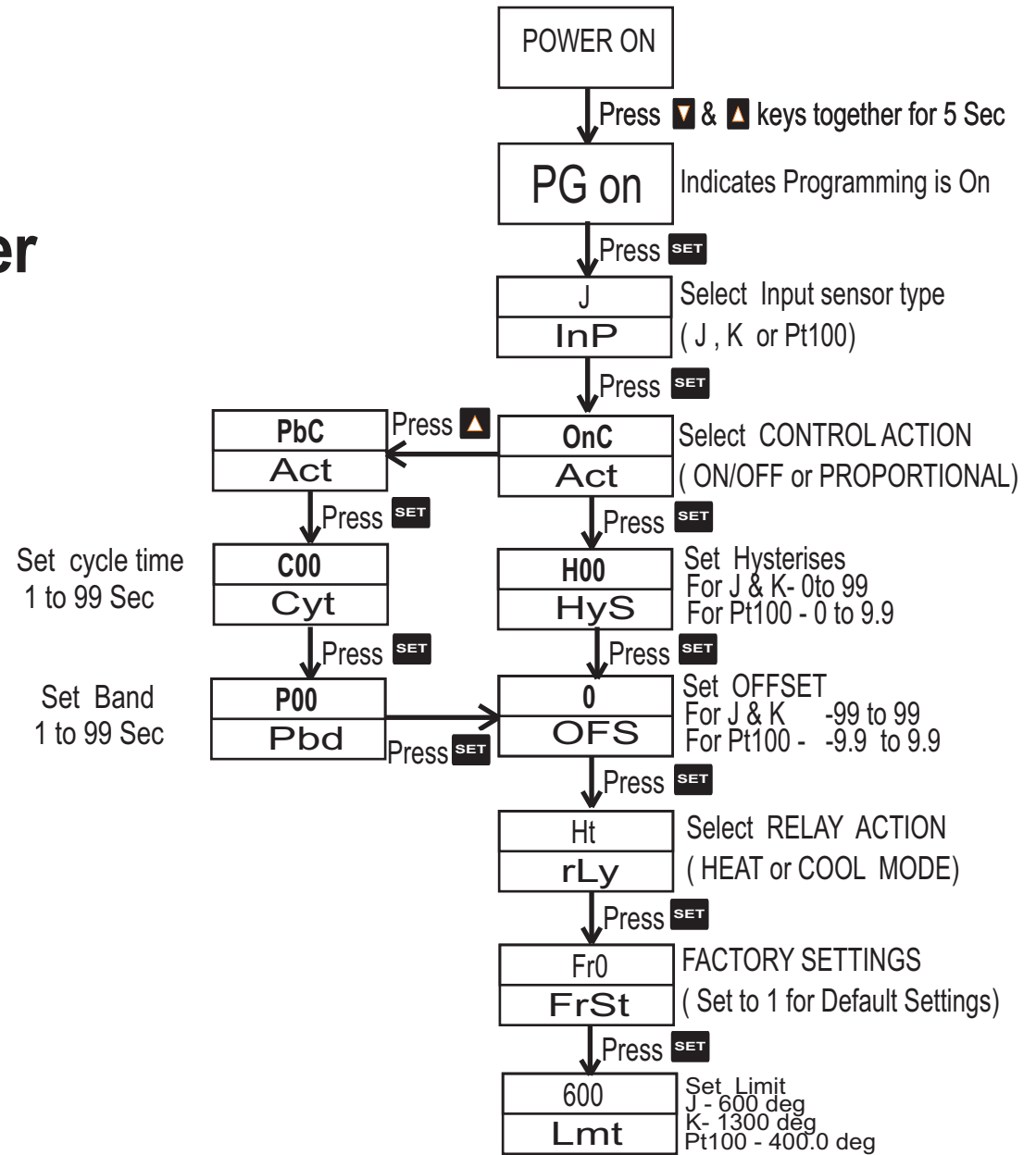

Note: To come out of Programming leave the Keys unpressed for more than 4 seconds or Switch off the Controller

Programming the Temperature Controller

Digital Temperature Controller

OPERATING INSTRUCTIONS

Specifications :-

- | | |
|-------------------|--|
| 1. Display | : .39" for PV & .20" for SV |
| 2. Range | : RTD Type -99.9 to 399.9 deg |
| | : J Type - 0- 600 deg |
| | : K Type 0 -1300 deg |
| 3. Resolution | : <u>1 deg(J/K) and 0.1 deg (RTD)</u> |
| 4. Accuracy | : +/- 0.5% (Full Scale) |
| 5- Hysterisis | : 0 to 99°C |
| 6. OFFSET | : -99 to 99°C |
| 7- Relay Action | : Heat / Cool Selectable |
| 8. Control Action | : ON / OFF or Proportional |

CYCLE TIME	: 1-99 Sec
Prop Band	: 0-99°C

Terminal Connection

- 1-Connect terminals of the controller according to the terminal connections

Set Point

Set Point can be viewed by pressing **SET** KEY.

Set Point can be changed by pressing **SET** KEY + **▼** & **▲** KEYS

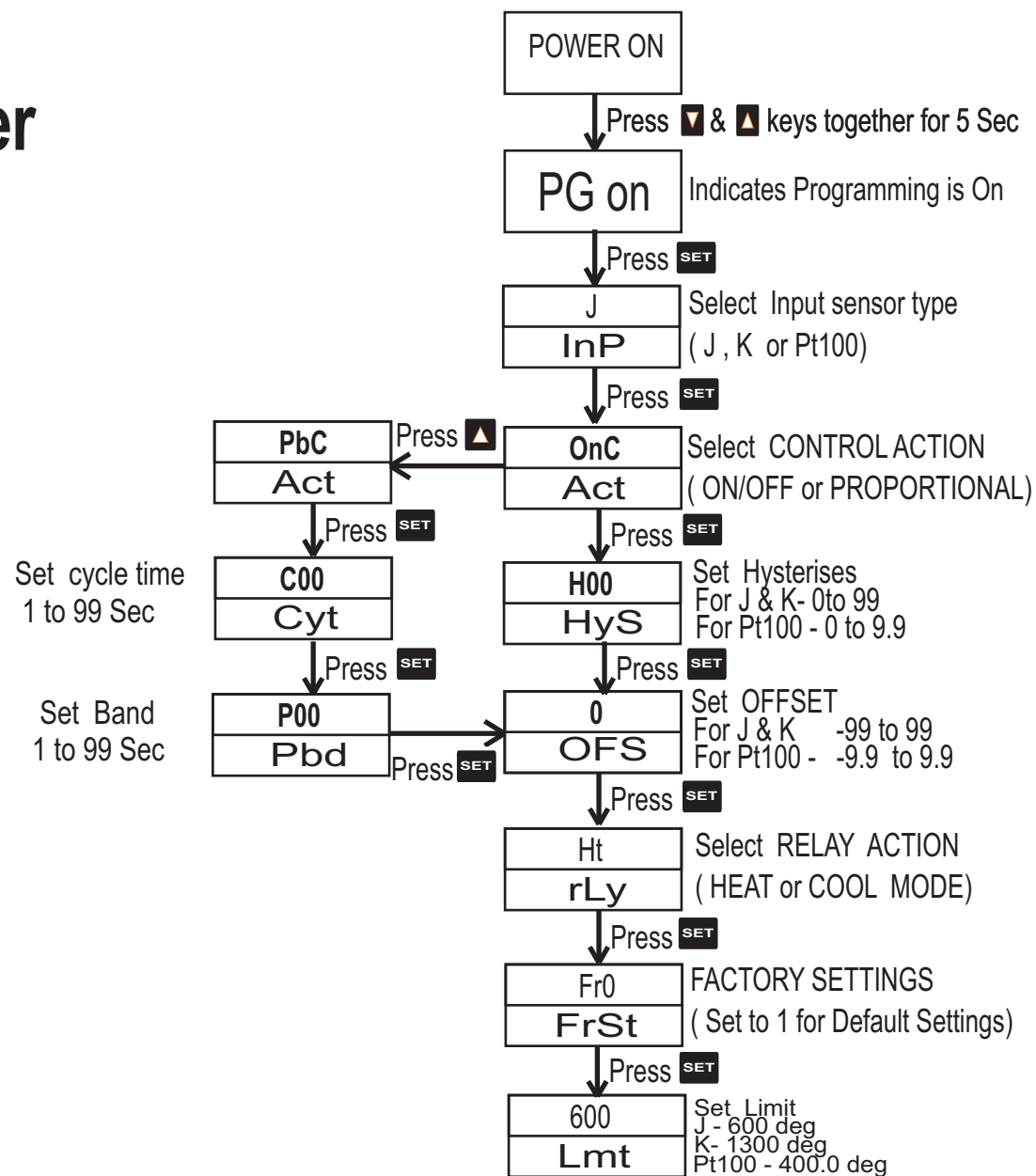

Note: To come out of Programming leave the Keys unpressed for more than 4 seconds or Switch off the Controller